

# SINGER

## PARTS LIST OF MODEL

144B8BL-20

144B8BL-30

145B28BL-20

145B28BL-30

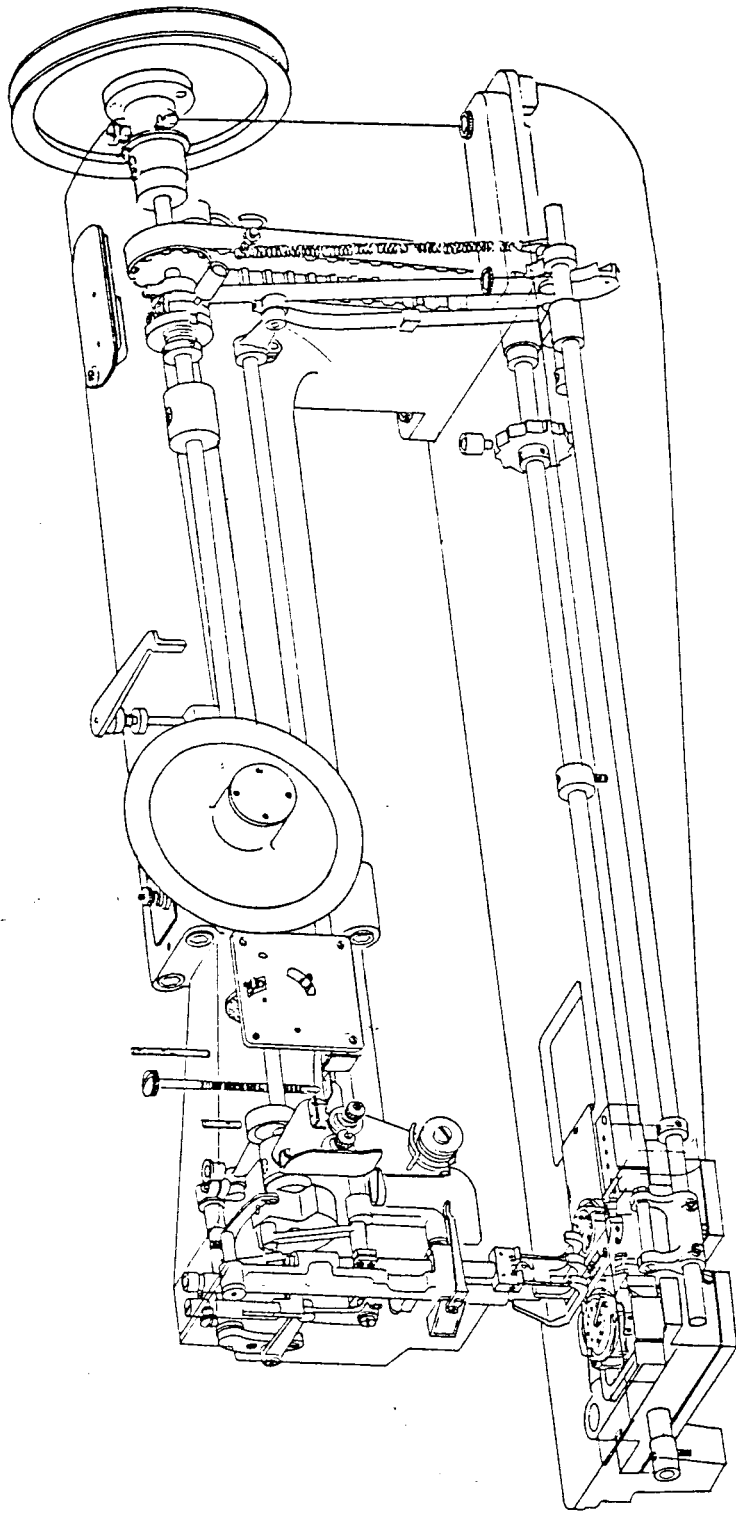
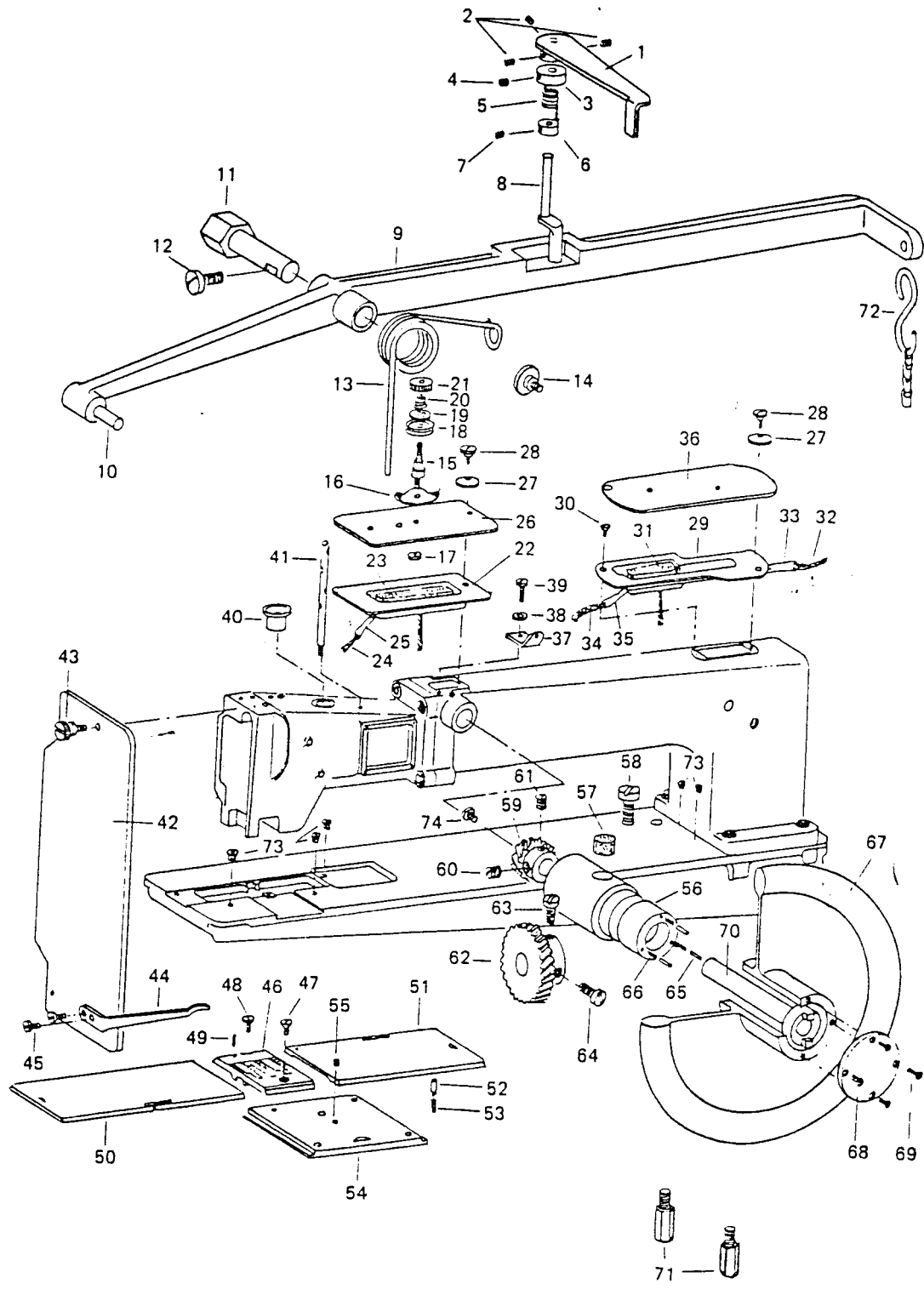

Fig. Nos.	Parts Nos.	Quantity	Description
1	70091	1	Foot lifter lifting lever latch handle.
2	2067	3	Set screw for 70091.
3	70089	1	Collar (upper) for 70088.
4	50287	1	Set screw for 70089.
5	70088	1	Foot lifter lifting lever latch spring.
6	70090	1	Collar (lower) for 70088.
7	50287	1	Set screw for 70090.
8	70087	1	Foot lifter lifting lever latch.
9	70083	1	Foot lifter lifting lever.
10	70084	1	Pin for 70083.
11	70085	1	Foot lifter lifting lever hinge stud.
12	10519	1	Pinch screw for 70085.
13	70086	1	Foot lifter lifting lever spring.
14	10548	1	Screw for 70086.
15	20018	1	Tension stud.
16	20025	1	Tension stud thread guide.
17	20021	1	Nut for 20018.
18	20019	2	Tension disc.
19	20020	1	Tension release disc.
20	70095	1	Tension spring.
21	20225	1	Tension thumb nut.
22	70082	1	Lubricating oil cup (front).
23	70115	1	Oil pad for 70082.
24	70180	1	Oil wick (A) for 70082.
25	70185	1	Vinyl tube (A) for 70082.
26	70081	1	Arm cap (front).
27	10703	2	Washer for 10704.
28	10704	2	Stop screw for 70081.
29	18103	1	Lubricating oil cup (back).
30	7041	1	Set screw for 18103.
31	18104	1	Oil pad for 18103.
32	70181	1	Oil wick (B) for 18103.
33	70186	1	Vinyl tube (B) for 18103.
34	70182	1	Oil wick (C) for 18103.
35	70187	1	Vinyl tube (C) for 18103.
36	18004	1	Arm cap (back).
37	70111	1	Bobbin winder thread guide.
38	30025	1	Washer for 8040.
39	8040	1	Stop screw for 70111.
40	70092	1	Arm oil plug.
41	10942	1	Thread guide.
42	70079	1	Face plate.
43	12611	1	Face plate thumb screw.
44	70080	1	Thread guide (lower).
45	10650	2	Screw for 70080.
46		1	Throat plate. [To be referred page 15 — 16]
47	6031	1	Throat plate screw.
48	11162	1	Throat plate position screw.
49	11163	1	Throat plate stop.
50		1	Bed slide (left). [To be referred page 15 — 16]
51		1	Bed slide (right). [To be referred page 15 — 16]
52	10667	1	Bed slide stop.
53	10668	1	Bed slide stop spring.
54	70214	1	Bed plate (front).
55	13085	1	Screw for 70214.
56	70043	1	Arm cross shaft bushing.
57	10725	1	Oil wick for 70043.
58	10519	1	Set screw for 70043.
59	35305	1	Arm cross shaft gear.
60	10658	1	Position screw (A) for 35405.
61	10566	1	Position screw (B) for 35405.
62	70046	1	Hand wheel driving gear.
63	70040	1	Set screw (A) for 70046.

\* Fig. Nos. from 64 to 74 are to be referred to the next page.

NOTE! WHEN ORDERING PARTS PREFIX ALL NUMBERS BY CS, EXAMPLE CS—



# 3

Fig. Nos.	Parts Nos.	Quantity	Description
64	12388	1	Set screw (B) for 70046.
65	35412	3	Hand wheel disengaging spring plunger.
66	35413	3	Hand wheel disengaging spring.
67	70041	1	Hand wheel.
68	70044	1	Hand wheel engaging plate.
69	12122	4	Screw for 70044.
70	70042	1	Arm cross shaft.
71	30137	2	Machine supporting bolt.
72	13079	1	Foot lifter lifting lever chain hook.
73	10794	5	Ball oiler.
74	10577	1	Arm cross shaft gear adjusting screw.

NOTE! WHEN ORDERING PARTS PREFIX ALL NUMBERS BY CS, EXAMPLE CS—

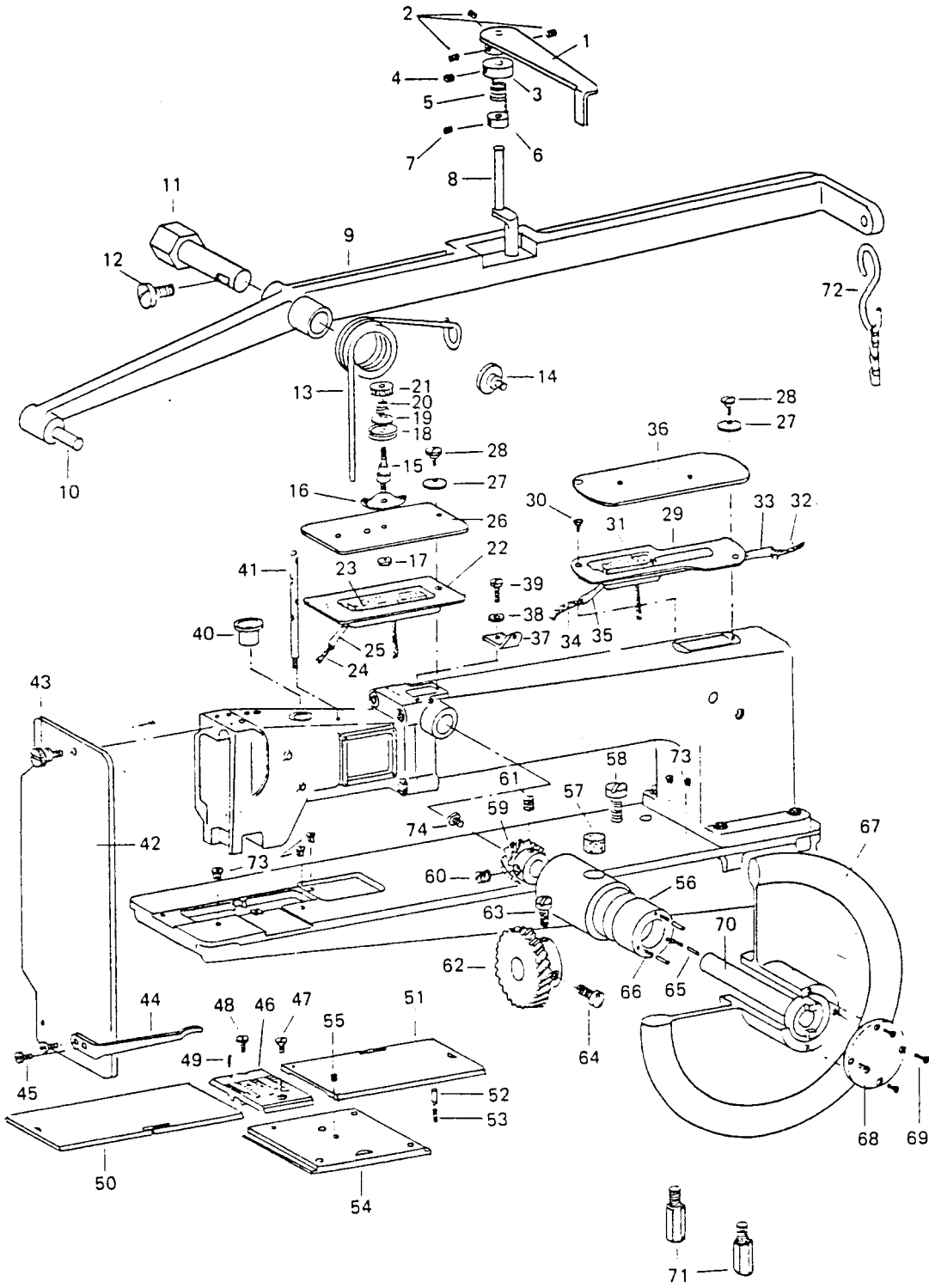
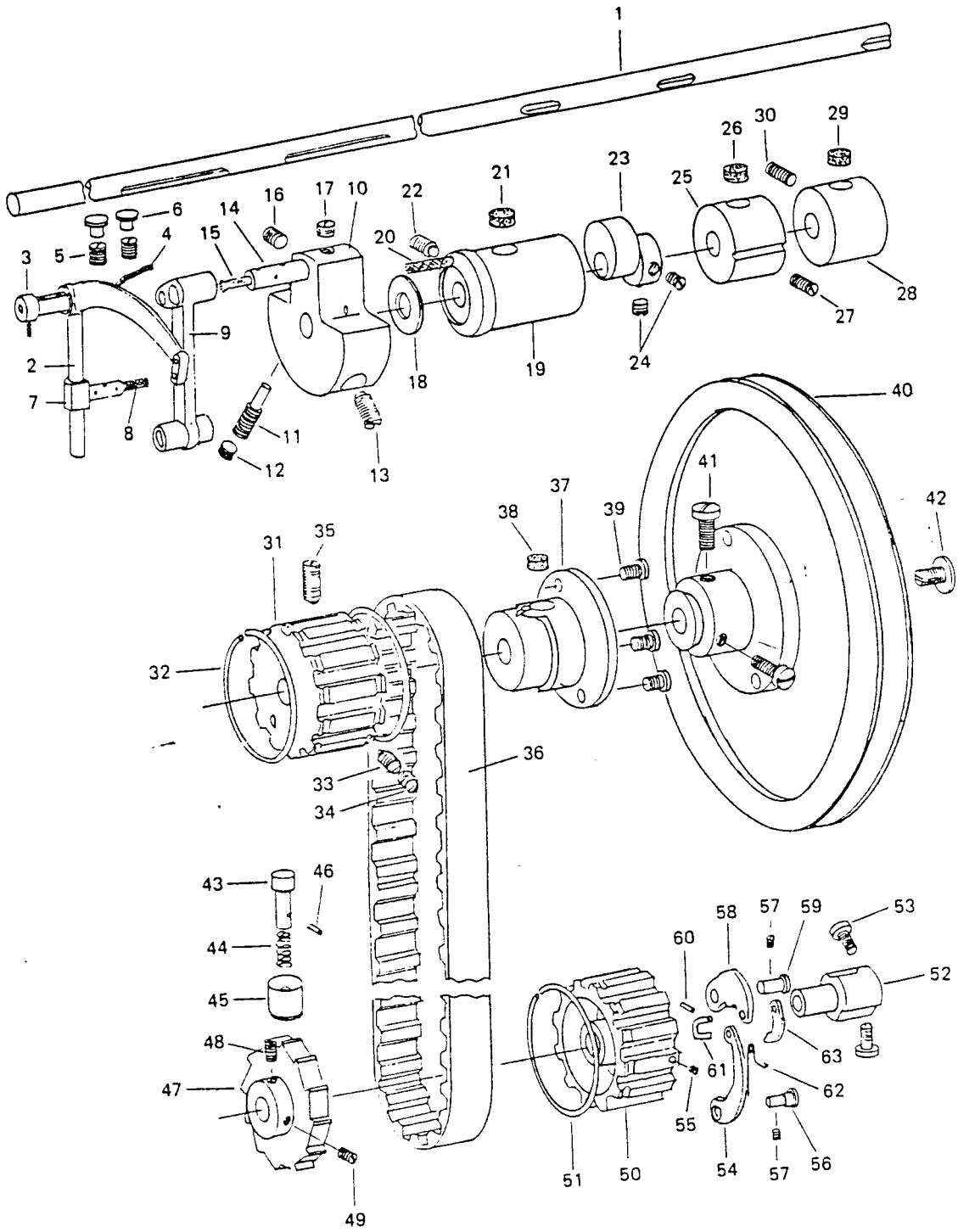

Fig. Nos.	Parts Nos.	Quantity	Description
1	70008	1	Arm shaft.
2	70018	1	Take-up lever.
3	70019	1	Take-up lever hinge stud.
4	11042	1	Oil wick for 70019.
5	10571	2	Set screw for 70019.
6	20172	2	Cap for 70019.
7	70020	1	Take-up lever driving stud.
8	10728	1	Oil wick for 70020.
9	70021	1	Needle bar connecting link.
10	70017	1	Needle bar crank.
11	10570	1	Position screw for 70017.
12	10524	1	Set screw (A) for 70017.
13	10522	1	Set screw (B) for 70017.
14	10523	1	Needle bar connecting link stud.
15	10726	1	Oil wick for 10523.
16	10524	1	Set screw (A) for 10523.
17	70016	1	Set screw (B) for 10523.
18	10563	1	Needle bar crank friction washer.
19	70007	1	Arm shaft bushing (front).
20	10725	1	Oil wick for 70007.
21	10729	1	Oil pad for 70007.
22	10571	1	Set screw for 70007.
23	70013	1	Feed driving eccentric.
24	10566	2	Set screw for 70013.
25	70009	1	Arm shaft center bushing (front).
26	10725	1	Oil pad for 70009.
27	10521	1	Set screw for 70009.
28	70010	1	Arm shaft center bushing (back).
29	10725	1	Oil pad for 70010.
30	10522	1	Set screw for 70010.
31	10569	1	Arm shaft connection belt pulley.
32	10574	1	Arm shaft connection belt pulley spring flange.
33	10761	1	Set screw for 10569.
34	10524	1	Check screw for 10569.
35	10571	1	Position screw for 10569.
36	10464WH	1	Connection belt.
37	70011	1	Arm shaft bushing (back).
38	10725	1	Oil pad for 70011.
39	50003	3	Set screw for 70011.
40	70093	1	Machine pulley.
41	10754	2	Set screw for 70093.
42	10577	1	Machine pulley adjusting screw.
43	13046	1	Hook driving shaft lock stud.
44	13047	1	Spring for 13046.
45	13045	1	Socket for 13046.
46	13048	1	Stop for 13046.
47	70139	1	Hook driving shaft lock ratchet.
48	10639	1	Set screw (A) for 70139.
49	10766	1	Set screw (B) for 70139.
50	70155	1	Safety clutch pulley.
51	10574	1	Safety clutch pulley spring flange.
52	10611	1	Safety clutch hook driving shaft position collar.
53	10612	2	Set screw for 10611.
54	70153	1	Safety clutch locking lever spring.
55	70154	1	Adjusting screw for 70153.
56	70169	1	Stud for 70154.
57	10581	2	Stop screw for 70169.
58	10616	1	Safety clutch locking lever.
59	10613	1	Stud for 10616.
60	10620	1	Safety clutch throw-in latch pin.
61	10618	1	Connecting link for 10616 & 70513.
62	10619	1	Safety clutch throw-in latch spring.
63	10617	1	Safety clutch throw-in latch.

NOTE: WHEN ORDERING PARTS PREFIX ALL NUMBERS BY CS, EXAMPLE CS—





# 7

Fig. Nos.	Parts Nos.	Quantity	Description
1	70201	1	Needle bar rock frame.
2	70028	1	Needle bar rock frame hinge stud.
3	10728	1	Oil wick for 70028.
4	70029	1	Set screw for 70028.
5	70022	1	Needle bar connection stud.
6	10726	1	Oil wick for 70022.
7	10532	2	Pinch screw for 70022.
8		1	Needle bar. (for 2-needle). [To be referred page 15 - 16]
9	70026	2/1	Needle. (CS213-01)
10	70025	2/1	Needle set screw.
11	70030	1	Needle bar rock frame position bracket.
12	15055	1	Screw for 70030.
13	70006	1	Presser bar position guide.
14	10761	1	Set screw for 10548.
15	10538	1	Presser bar bushing (upper).
16	10761	1	Set screw for 10538.
17	70032	1	Presser bar position guide lever.
18	10662	1	Pinch screw for 70032.
19	70033	1	Presser bar lifting bracket.
20	10545	1	Pinch screw for 70033.
21	70034	1	Presser bar spring bracket.
22	70035	1	Pinch screw for 70034.
23	10539	1	Presser bar bushing (lower).
24	70031	1	Presser bar.
25		1	Lifting presser foot. [To be referred page 15 - 16]
26	10749	1	Pinch screw for lifting presser foot.
27	70015	1	Lifting rock shaft.
28	10514	2	Lifting rock shaft bushing.
29	15053	1	Screw stud for 70015.
30	10728	1	Oil wick for 15053.
31	10517	1	Nut for 15053.
32	70014	1	Lifting eccentric.
33	10754	1	Position screw for 70014.
34	70012	1	Lifting eccentric connection.
35	70036	1	Lifting bell crank.
36	10559	1	Set screw for 70036.
37	70038	1	Lifting bell crank link.
38	70037	1	Vibrating presser bar connecting link.
39	70202	1	Vibrating presser bar. (for 2-needle)
40	10728	1	Oil wick for 70202.
41		1	Vibrating presser foot. [To be referred page 15 - 16]
42	141158	1	Set screw for vibrating presser foot.
43	70055	1	Needle bar rock frame rock shaft.
44	10582	1	Needle bar rock frame slide block.
45	10580	1	Screw stud for 10582.
46	10581	1	Set screw for 10580.
47	70056	1	Needle bar rock frame rock shaft crank.
48	10754	1	Pinch screw for 70056.
49	70057	1	Needle bar rock frame rock shaft crank connection.
50	10728	1	Oil wick for 70057.
51	13134	1	Hinge screw for 70057.
52	10586	1	Nut for 13134.
53	70059	1	Feed reversing crank screw stud.
54	70058	1	Feed reversing crank.
55	11185	1	Nut for 70058.
56	10754	1	Stop screw for 70058.
57	70113	1	Vibrating presser foot (for Single needle)
58	70114	1	Lifting presser foot. (for Single needle)
59	70188	1	Vinyl tube.
60	70039	1	Vibrating presser bar. (for Single needle)
61	10677	1	Washer for 10749.
62	20272	1	Nut for 10749.

NOTE! WHEN ORDERING PARTS PREFIX ALL NUMBERS BY CS, EXAMPLE CS\_\_\_

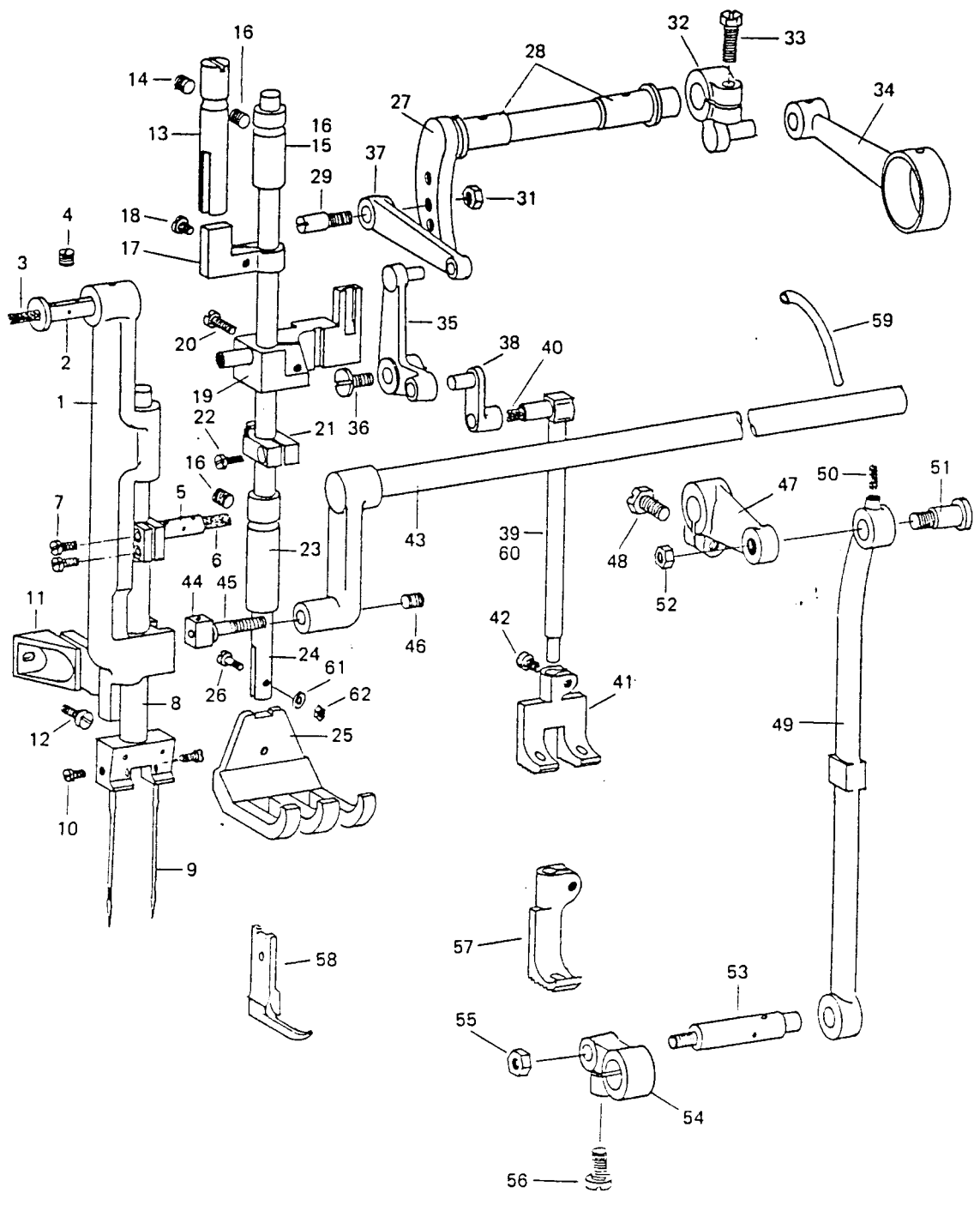

Fig. Nos.	Parts Nos.	Quantity	Description
1	70050	1	Feed driving eccentric.
2	70049	1	Flange for 70050.
3	11093	1	Set screw (A) for 70049.
4	11094	1	Set screw (B) for 70049.
5	11095	1	Friction plate.
6	11096	2	Stop screw for 11095.
7	2067	2	Set screw for 11096.
8	70051	1	Feed driving eccentric adjusting disc.
9	11099	1	Spring for 70051.
10	70052	1	Collar for 11099.
11	10639	2	Position screw for 70052.
12	10566	2	Set screw for 70052.
13	70054	1	Feed regulating stud.
14	12383	1	Spring for 70054.
15	70053	1	Bushing for 70054.
16	15076	1	Retaining spring for 70054.
17	70047	1	Feed driving connection.
18	10545	1	Pinch screw for 70047.
19	10728	1	Oil wick for 70047.
20		1	Feed dog. [To be referred page 15 — 16]
21	70118	2	Feed dog set screw.
22	70217	1	Feed bar, - 2 needle.
23	70128	1	Feed lifting cam fork.
24	10599	1	Washer for 70128.
25	70129	1	Screw for 70128.
26	10596	1	Oiling pad for 70128.
27	10597	1	Screw for 10596.
28	70126	1	Feed bar crank.
29	12408	2	Set screw for 70126.
30	10602	1	Feed bar hinge screw.
31	10636	1	Nut for 10602.
32	70122	1	Feed driving rock shaft.
33	10593	1	Feed driving rock shaft stop collar (A).
34	10764	1	Set screw for 10593.
35	70123	1	Feed driving rock shaft stop collar (B).
36	13033	1	Set screw for 70123.
37	70162	1	Feed reversing lever.
38	70160	1	Feed reversing lever bushing.
39	70161	1	Collar for 70160.
40	10561	1	Set screw for 70161.
41	70048	1	Hinge screw for 70162.
42	10728	1	Oil wick for 70048.
43	11185	1	Nut for 70048.
44	70163	2	Stop screw for 70162.
45	70165	1	Feed reversing lever slide block.
46	70164	1	Hinge screw for 70165.
47	70166	1	Feed reversing link.
48	70159	1	Spring and treadle connecting link for 70165.
49	70167	1	Hinge screw nut for 70165.
50	70168	1	Hinge screw for 70165.
51	10728	1	Oil wick for 70168.
52	11185	1	Nut for 70168.
53	70124	1	Feed reversing crank.
54	10754	1	Bracket screw for 70124.
55	70158	1	Feed reversing lever slide block spring.
56	70156	1	Connection collar for 70158.
57	70157	2	Nut for 70156.
58	11097	2	Lining metal for 11096.

NOTE! WHEN ORDERING PARTS PREFIX ALL NUMBERS BY CS, EXAMPLE CS\_\_\_

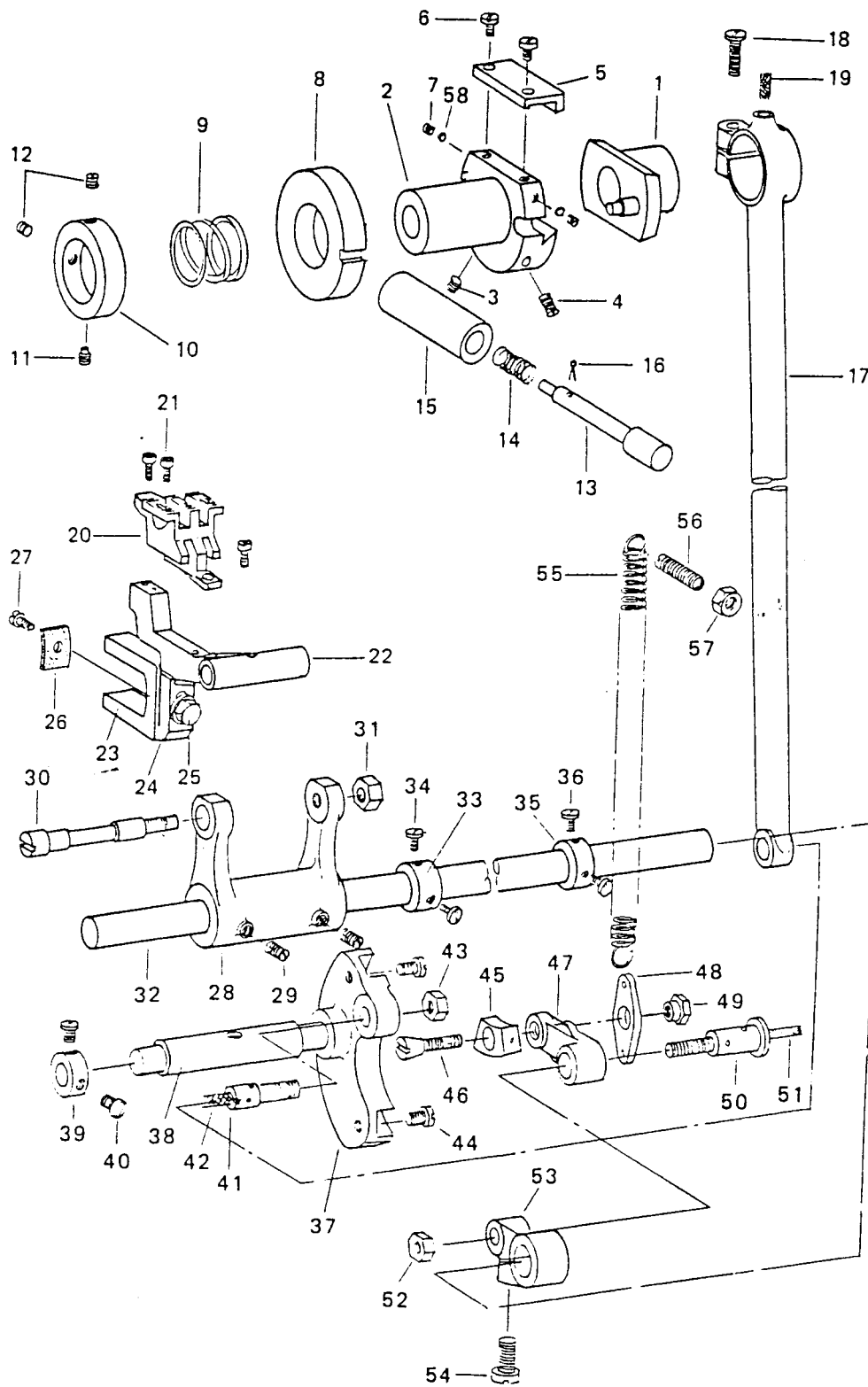

Fig. Nos.	Parts Nos.	Quantity	Description
1	70152	2/1	Oil gauge.
2	11131	2/1	Oil gauge guide.
3	70149	2/1	Bobbin case opener lever.
4	70150	2/1	Bobbin case opener lever hinge stud.
5	10727	2/1	Oil wick for 70150.
6	11137	2/1	Oil wick vinyl tube for 70150.
7	70146	2/1	Bobbin case opener.
8	70148	2/1	Washer for 70146.
9	70147	2/1	Screw for 70146.
10	70141		Bobbin.
11	70140	2/1	Hook.
12	70151	2/1	Bobbin case opener lever link.
13	10651	2/1	Bobbin case opener lever driving screw stud.
14	10727	2/1	Oil wick for 10651.
15	10652	2/1	Nut for 10651.
16	70145	2/1	Hook bushing (upper).
17	11176	2/1	Set screw for 70145.
18	70132	1	Hook driving shaft bushing (front). Lower shaft center metal, for single-needle.
"	"	2	" Available to up to 5/8" (16 mm) for 2-needle.
"	70132A	1	" (for 70142) } Available to 3/4" (19 mm)
"	70132B	1	" (for 70203) } 1-1/2" (38 mm) for 2-needle.
19	11080	2	Oiling felt for 70132.
20	10571	2	Set screw for 70132.
21	70203	1	Hook saddle (left).
22	70142	1	Hook saddle (right).
23	15092	2/1	Gasket for hook saddle.
24	15521	1	Oil reservoir (left).
25	15091	1	Oil reservoir (right).
26	15007	14/7	Screw for 15091.
27	11145	2/1	Hook saddle screw collar (A).
28	11146	2/1	Hook saddle screw collar (B).
29	11144	2/1	Hook saddle screw.
30	70143	2/1	Bed block.
31	70144	4/2	Bed block screw.
32	10638	2/1	Hook driving gear.
33	70137	2/1	Set screw (A) for 10638.
34	70138	2/1	Set screw (B) for 10638.
35	10657	2/1	Hook driving pinion.
36	10658	2/1	Set screw (A) for 10657.
37	10767	2/1	Set screw (B) for 10657.
38	10644	2/1	Hook driving pinion thrust washer.
39	15096	2/1	Hook bushing (lower).
40	11176	2/1	Set screw for 15096.
41	15093	2/1	Oil adjusting dial.
42	15094	2/1	O-ring for 15093.
43	10629	2/1	Set screw for 15093.
44	10647	2/1	Washer for 10646.
45	10646	2/1	Hook saddle screw.
46	10637	1	Feed lifting cam.
47	10658	1	Set screw for 10637.
48	10573	2/1	Set screw for 70150.
49	10729	1	Oil wick for 70132.
50	10519	1	Set screw for 70132.
51	10131	1	Hook driving shaft.
52	70134	1	Hook driving shaft bushing (center).
53	11080	1	Oil pad for 70134.
54	10766	1	Set screw for 70134.
55	70130	1	Hook driving shaft collar.
56	10764	2	Position screw for 70130.
57	70135	1	Hook driving shaft bushing (back).
58	10725	2	Oiling pad for 70135.
59	70136	1	Set screw for 70135.
60	12135	1	Lower shaft front metal. (for Single needle 20" & 30")

NOTE! WHEN ORDERING PARTS PREFIX ALL NUMBERS BY CS, EXAMPLE CS\_\_\_

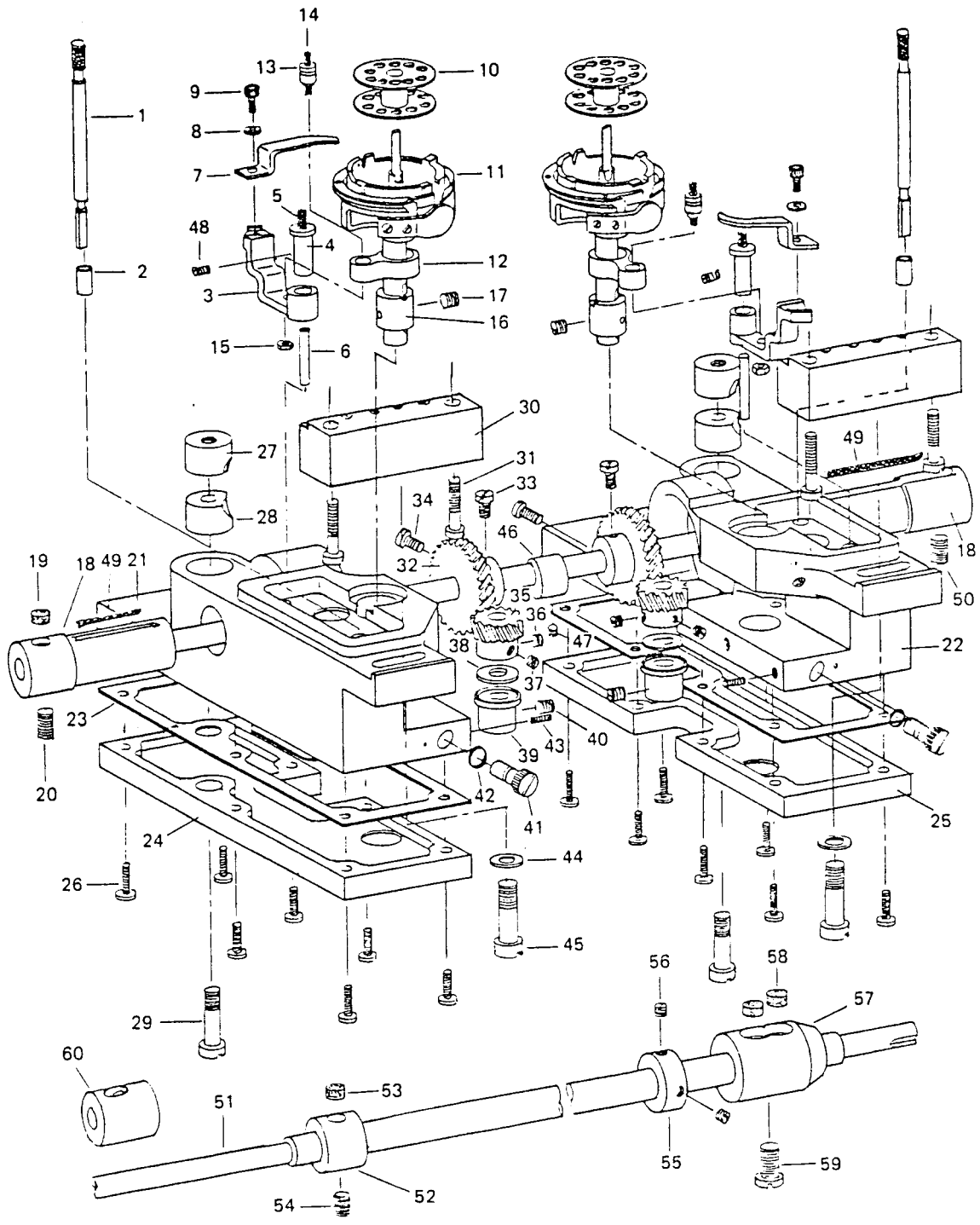
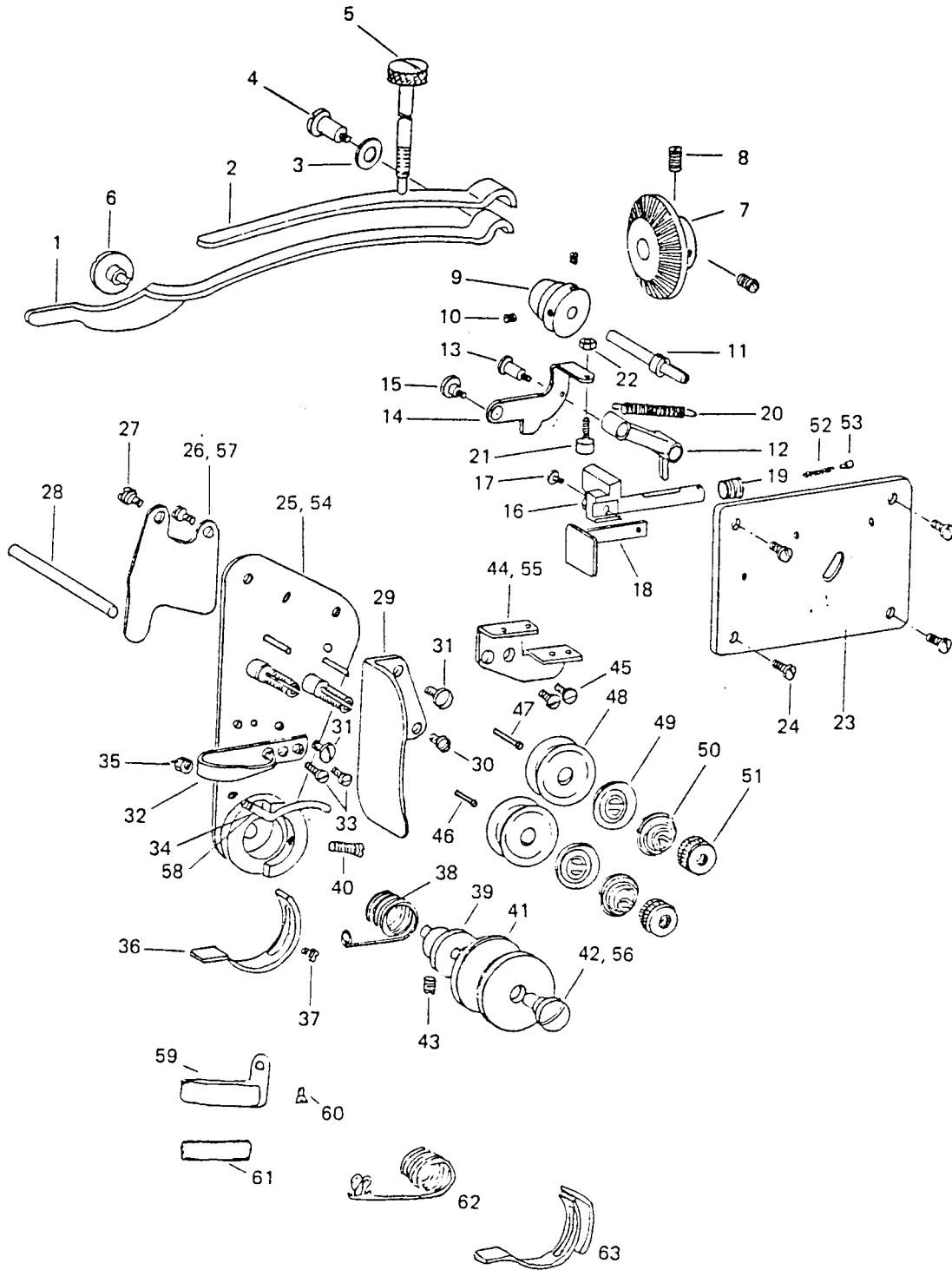

Fig. Nos.	Parts Nos.	Quantity	Description
1	70060	1	Presser bar spring (flat).
2	70061	1	Presser bar spring (auxiliary).
3	70094	1	Presser bar spring support screw washer.
4	70121	1	Presser bar spring support screw.
5	70062	1	Presser bar spring regulating screw.
6	10548	1	Presser bar lifting bracket guide screw.
7	70112	1	Bobbin winder driving gear.
8	10766	2	Set screw for 70112.
9	70101	1	Bobbin winder shaft driving roller.
10	70175	2	Set screw for 70101.
11	70100	1	Bobbin winder shaft.
12	70099	1	Bobbin winder link.
13	70103	1	Screw stud for 70099.
14	70102	1	Bobbin winder connecting plate.
15	70104	1	Stop screw for 70102.
16	70110	1	Bobbin winder releasing lever.
17	4094	1	Set screw for 70109.
18	70109	1	Bobbin winder set lever.
19	70108	1	Releasing spring for 70110.
20	70107	1	Releasing spring for 70102.
21	70106	1	Bobbin winder adjusting screw.
22	4137	1	Nut for 70106.
23	70097	1	Bobbin winder bracket.
24	15055	4	Set screw for 70097.
25	70204	1	Tension bracket. (for 2-needle)
26	70206	1	Tension release lever. (for 2-needle)
27	10679	2	Screw for tension release lever.
28	70074	1	Tension release plunger.
29	70075	1	Thread controller covering plate.
30	10650	1	Stop screw for 70075.
31	10561	2	Stop screw for 70075.
32	70077	1	Thread guide (lower).
33	12113	2	Screw for 70077.
34	70210	1	Thread controller thread guide (lower). (for 2-needle)
35	11067	1	Nut for 70078.
36	70073	1	Thread controller spring stop. (for Single needle)
37	10650	1	Stop screw for 70073.
38	70072	1	Thread controller spring. (for Single needle)
39	70070	1	Thread controller spring stud.
40	15055	1	Set screw for 70070.
41	70069	1	Thread controller disc.
42	70208	1	Thread controller stud. (for 2-needle)
43	12421	1	Set screw for thread controller stud.
44	70209	1	Thread controller thread guide. (for 2-needle)
45	12113	2	Set screw for 70209.
46	70066	1	Tension release plunger (short).
47	70207	1	Tension release plunger (long). (for 2-needle)
48	8077	2/1	Tension disc.
49	3071	1	Tension disc.
50	8078	2/1	Tension spring.
51	8079	2/1	Tension thumb nut.
52	70105	1	Releasing spring for 70096.
53	70096	1	Stop stud for 70099.
54	70063	1	Tension bracket. (for Single needle)
55	70076	1	Thread controller thread guide. (for Single needle)
56	70071	1	Thread controller stud. (for Single needle)
57	70067	1	Tension release lever. (for Single needle)
58	70078	1	Thread controller thread guide (lower). (for Single needle)
59	10759	1	Thread guide.
60	10685	1	Set screw for 10759.
61	10760	1	Felt.
62	70221	1	Thread controller spring. (for 2-needle)
63	70222	1	Thread controller spring stop. (for 2-needle)

NOTE! WHEN ORDERING PARTS PREFIX ALL NUMBERS BY CS, EXAMPLE CS\_\_









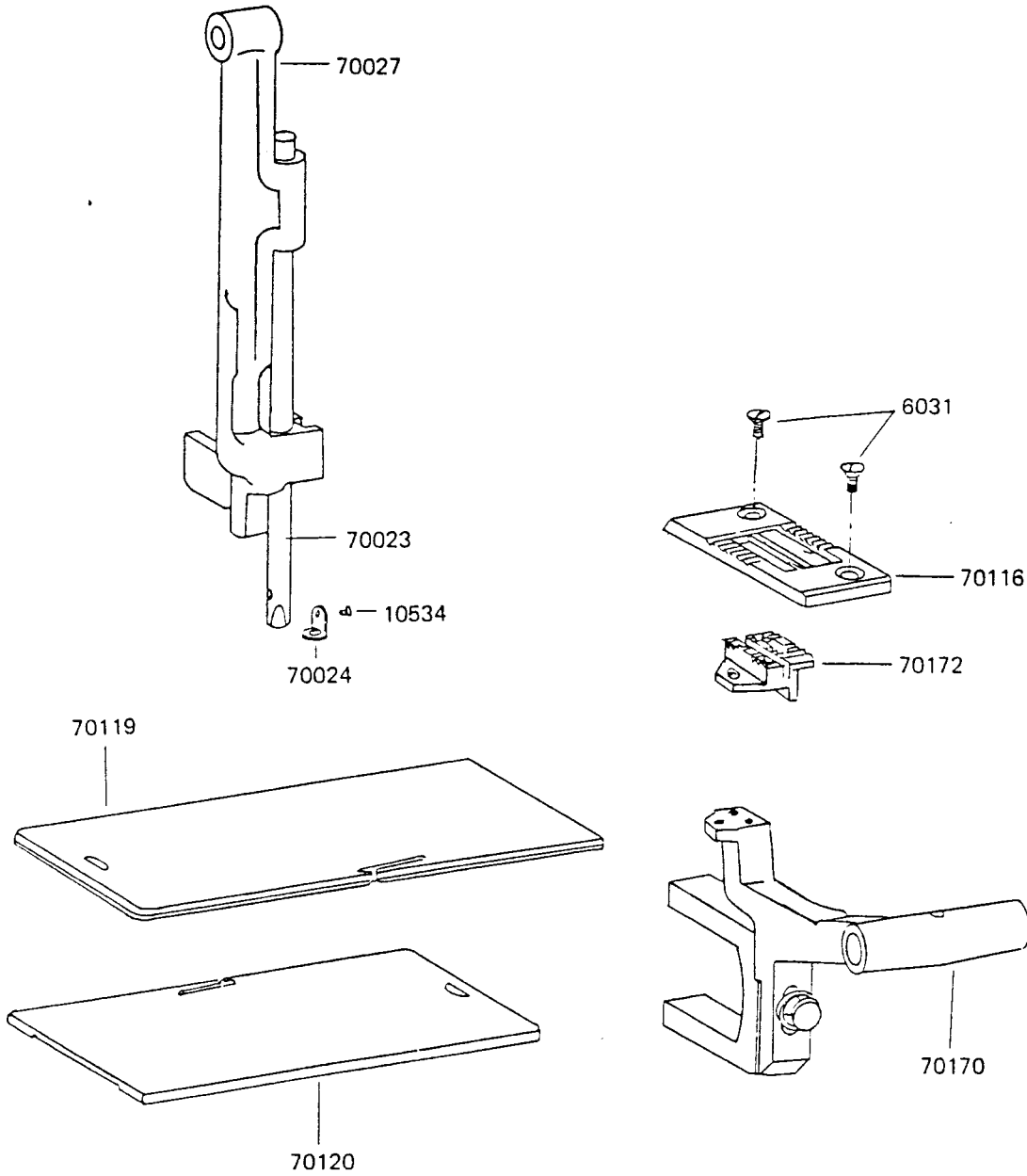





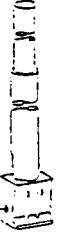

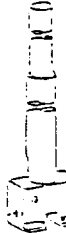
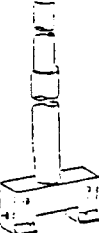
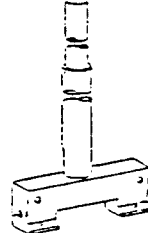
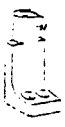



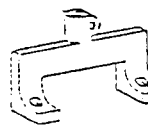

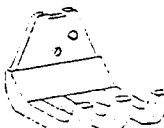

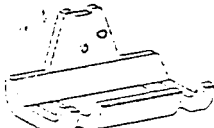

# 15

For Single Needle

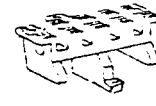

4

For 2-Needle

				
1/4"-70230 5/16"-70232 8.3mm-70248	3/8"-70233 7/16"-70234 1/2"-70235 9/16"-70236A 14mm-70236B 5/8"-70237 10mm-70249	3/4"-70238 7/8"-70239	1"-70240 1-3/16"-70241 1-1/4"-70242	1-3/8"-70243 1-1/2"-70244 1-3/4"-70245 2-3/8"-70247
				
1/4"-70250 5/16"-70252 8.3mm-70268	3/8"-70253 7/16"-70254 1/2"-70255 9/16"-70256A 14mm-70256B 5/8"-70257 10mm-70269	3/4"-70258 7/8"-70259	1"-70260 1-3/16"-70261 1-1/4"-70262	1-3/8"-70263 1-1/2"-70264 1-3/4"-70265 2-3/8"-70267
				
1/4"-70270 5/16"-70272 8.3mm-70288	3/8"-70273 7/16"-70274 1/2"-70275 14mm-70276 9/16"-70276 5/8"-70277 10mm-70289	3/4"-70278 7/8"-70279	1"-70280 1-3/16"-70281 1-1/4"-70282	1-3/8"-70283 1-1/2"-70284 1-3/4"-70285 2-3/8"-70287
				
1/4"-70290 5/16"-70292 8.3mm-70308	3/8"-70293 7/16"-70294 1/2"-70295 14mm-9/16"-70296 10mm-70309	5/8"-70297 3/4"-70298 7/8"-70299	1"-70300 1-3/16"-70301 1-1/4"-70302	1-3/8"-70303 1-1/2"-70304 1-3/4"-70305 2-3/8"-70307
				
1/4"-70310 5/16"-70312 8.3mm-70328	3/8"-70313 7/16"-70314 1/2"-70315 9/16"-70316A 14mm-70316B 10mm-70329	5/8"-70317 3/4"-70318 7/8"-70319	1"-70320 1-3/16"-70321 1-1/4"-70322	1-3/8"-70323 1-1/2"-70324 1-3/4"-70325 2-3/8"-70327
				
1/4"-70218 10mm-3/8"-70333 7/16"-1/2"-70335 9/16"-14mm-70335	5/8"-70337 3/4"-70338 7/8"-70339 1"-70340 1-1/4"-70342	1-3/8"-70343 1-1/2"-70344 1-3/4"-70345 2-3/8"-70347 8.3mm-70348 5/16"-70348	1/4"-70224 3/8"-70353 10mm-70353	7/16"-1/2"-70355 14mm-9/16"-70355 5/8"-70357 3/4"-70358 7/8"-70359 1"-70360 1-1/4"-70362 1-3/16"-70362 1-3/8"-70363 1-1/2"-70364 1-3/4"-70365 2-3/8"-70367 8.3mm-70368 5/16"-70368

NOTE! WHEN ORDERING PARTS PREFIX ALL NUMBERS BY CS, EXAMPLE CS—

## SPECIAL PARTS FOR 20"

Fig. Nos.	Parts Nos.	Quantity	Description
1	70376	1	Lifting lever.
2	70372	1	Main shaft.
3	70373	1	Needle bar frame rock shaft.
4	70375	1	Feed driving rock shaft.
5	70374	1	Hook driving shaft.

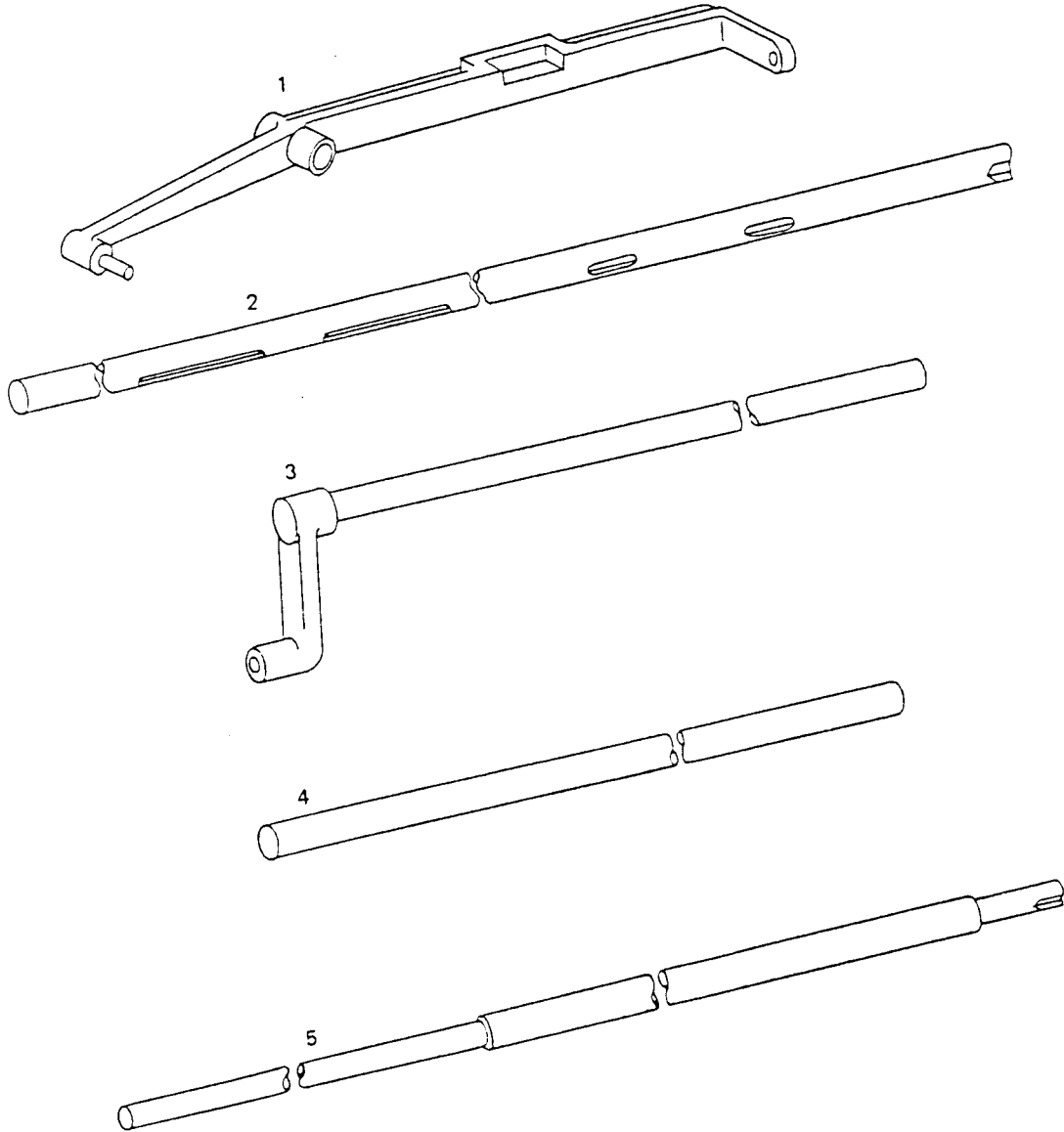

NOTE! WHEN ORDERING PARTS PREFIX ALL NUMBERS BY CS, EXAMPLE CS—



## ACCESSORIES

Fig. Nos.	Parts Nos.	Quantity	Description
1	8132	1	Accessories box.
2	70141	3	Bobbin.
3	8118	1	Screw driver (large).
4	8120	1	Screw driver (middle).
5	8121	1	Screw driver (small)
6	15571	1	Wrench 4.0 mm.
7	15572	1	Wrench 3.0 mm.
8	11969	1	Wrench 2.5 mm.
9	10747	1	Wrench 1.5 mm.
10	10748	1	Double head wrench.
11	70171	1	Oil pan.
	70517	1	Oil pan (for puller type).
12	6055	10	Nail for No. 70171 & 70517.
13	10942	1	Spool pin.
14	N 33	3	Needle ( 5213-01 )
15	8125	1	Oiler.
16	11193	1	Oil.
17	35254C	1 set	Thread stand. (for Single needle)
	10947	1 "	" (for 2-needle)
18	13079	1	Chain.
19	11171	1	Bed hinge.
	6052	4	Screw for No. 11171.
	11169	1	Bed hinge.
	11170	4	Screw for No. 11169.

NOTE! WHEN ORDERING PARTS PREFIX ALL NUMBERS BY CS, EXAMPLE CS\_\_\_

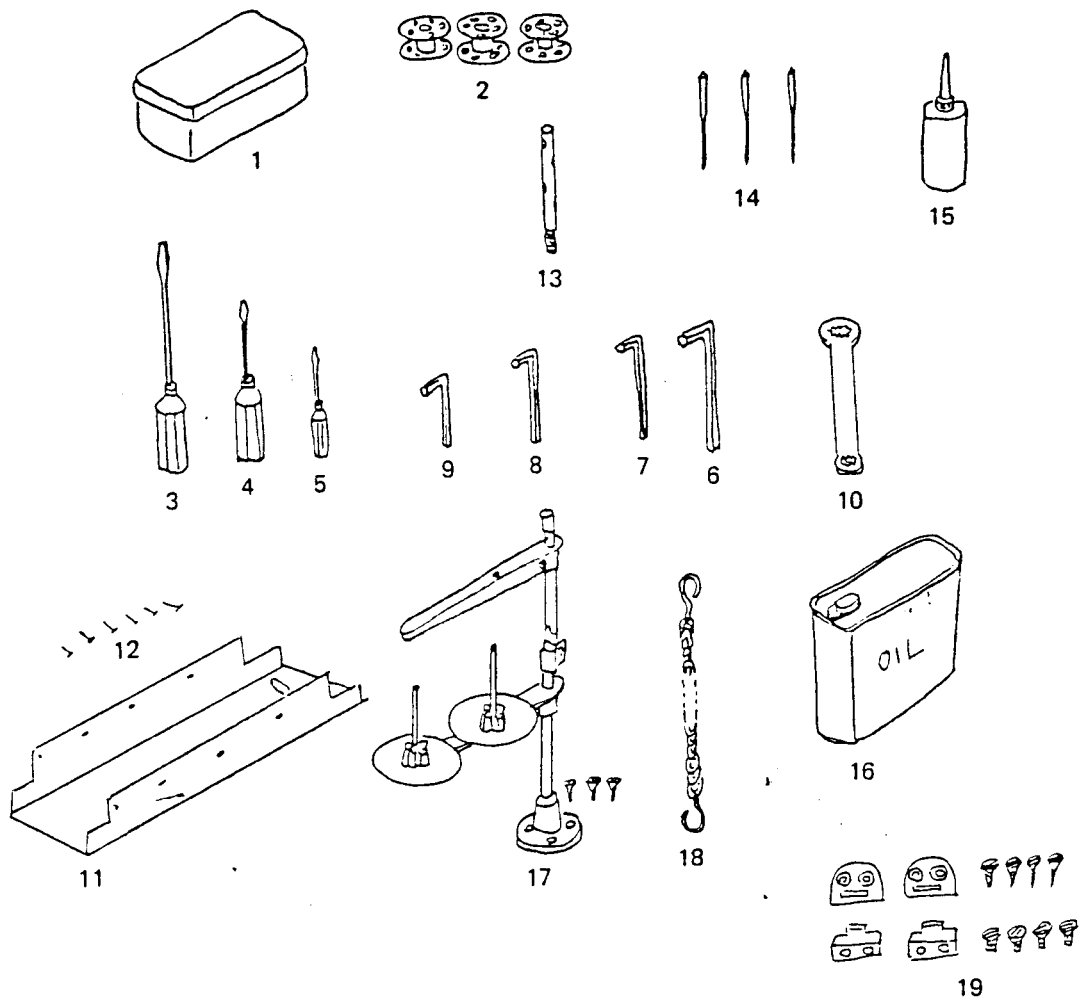

# 21

## BELT GUARD (OPTIONAL)

Fig. Nos.	Parts Nos.	Quantity	Description
20	70199C	1 set	Belt guard.
21	70189	1	Fixing stand for synchronizer.
22	35028C	1 set	Adaptor for synchronizer.

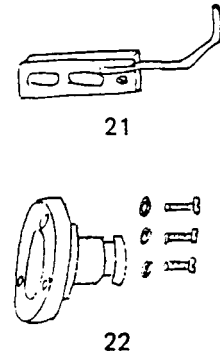
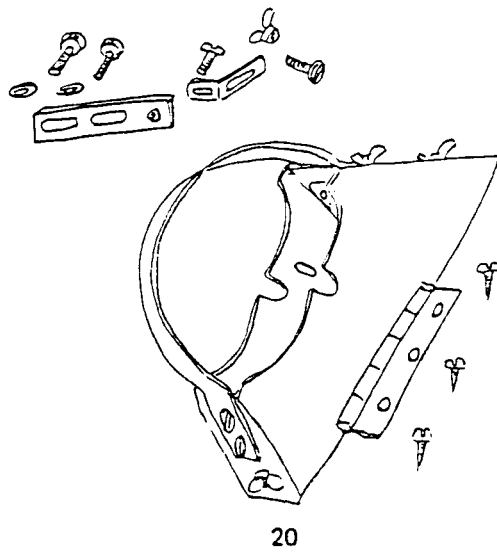

NOTE! WHEN ORDERING PARTS PREFIX ALL NUMBERS BY CS, EXAMPLE CS\_\_

